

DATA0..7  
= Berg 33, 31, ... 19  
= Debian GPIO 32..39

BBB-UART DSUB9 to 2x5 RS232 pin header

Relay passive: UART/SLU connected to extern case connector  
Relay active: LSI SLU internally connected to BBB UART

LSI11 DLV11 SLU standard usage:  
A = console @ 176560  
B = 176500 (TU58)  
C = 176510  
D = 176520  
DEC designations for A..D differ!

BBB console UART to Cape TTY5

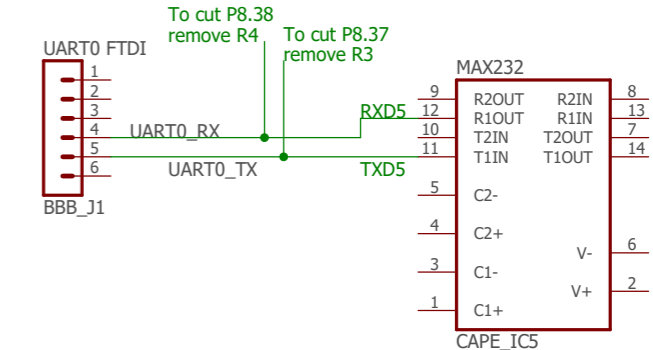

baseboard
nicht gespeichert!
Sheet: 1/1